



**KOLEJ UNIVERSITI TEKNIKAL KEBANGSAAN MALAYSIA  
PEPERIKSAAN SEMESTER 2  
SESI 2003/2004  
FAKULTI KEJURUTERAAN PEMBUATAN**

**SUBJECT CODE** : **DMFD 2833**  
**SUBJECT** : **FLUID MECHANICS**  
**COORDINATOR** : **EN. D.SUGUMAR/ PROF. MADYA CHONG  
KUAN ENG**  
**COURSE** : **DIPLOMA KEJURUTERAAN  
PEMBUATAN**  
**SECTION** : **1**  
**TIME** : **2 hours 30 minutes**  
**DATE** : **MARCH 2004**

---

**INSTRUCTIONS TO CANDIDATES:**

- 1) There are a total of six (6) questions in this paper. Answer any four (4) questions only.
- 2) Draw suitable sketches or line diagrams wherever necessary
- 3) Start each question in a new answer sheet.

---

**THIS PAPER CONSISTS OF FOUR (7) PAGES (INCLUDING FRONT PAGE)**

**Question 1**

(a) Explain the following terms:

- |       |                     |           |
|-------|---------------------|-----------|
| (i)   | Newtonian Fluid     | [2 marks] |
| (ii)  | Non Newtonian Fluid | [2 marks] |
| (iii) | Mass density        | [2 marks] |
| (iv)  | Kinematic viscosity | [2 marks] |
| (v)   | Surface tension     | [2 marks] |

(b) The density of SAE 40 lubrication oil inside a 200 liter drum is  $850 \text{ kg/m}^3$ . Find its relative density and kinematic viscosity if the dynamic viscosity is  $5 \times 10^{-3} \text{ kg/ms}$ .

[10 marks]

(c) Air is introduced through a nozzle into a tank of water to form a stream of bubbles. If the bubbles are intended to have a diameter of 3.5 mm, calculate by how much the pressure of air at the nozzle must exceed that of the surrounding water. Assume that the surface tension,  $\sigma = 72.7 \times 10^{-3} \text{ Nm}^{-1}$ .

[5 marks]

## Question 2

(a) Show that pressure at a point of a fluid at rest is the same in all directions.

[10 marks]

(b) For the manometer shown below calculate the difference of pressure,

$$P_A - P_B$$

assuming relative density of oil is 0.8.

[15 marks]

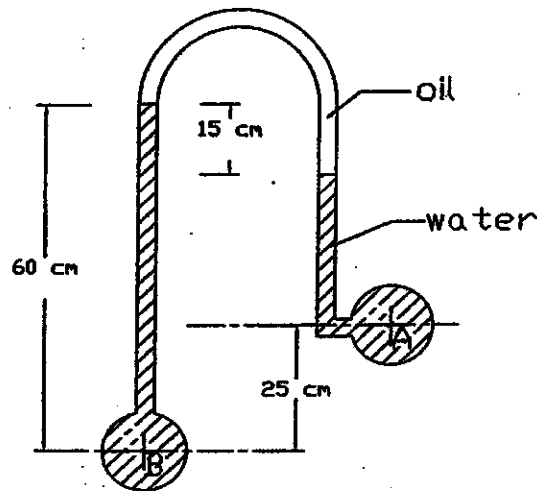

**Question 3**

- (a) One end of a rectangular tank is 2.0 meter wide by 3.5 meter deep. The tank is completely filled with oil of specific weight  $11 \text{ kNm}^{-3}$ . Calculate
- (i) the resultant pressure on this vertical end [5 marks]
  - (ii) the depth of the centre of pressure from the top [5 marks]
- (b) A rectangular shaped instrument carrying buoy with a width of 7 meter, a length of 12 meter has a draught of 2.4 meter in fresh water (density of  $1000 \text{ kg m}^{-3}$ ). Calculate the
- (i) the weight of the pontoon [5 marks]
  - (ii) its draught in sea water (density  $1055 \text{ kg m}^{-3}$ ) [5 marks]
  - (iii) load (in newtons) that can be supported by the pontoon in fresh water if the maximum draught allowed is 3.2 meter. [5 marks]

## Question 4

- (a) Calculate the magnitude and direction of the resultant force on the block shown below, due to the flow of water. Assume that the velocity is constant at 15 m/s and density of water is  $1000 \text{ kg / m}^3$ . [15 marks]

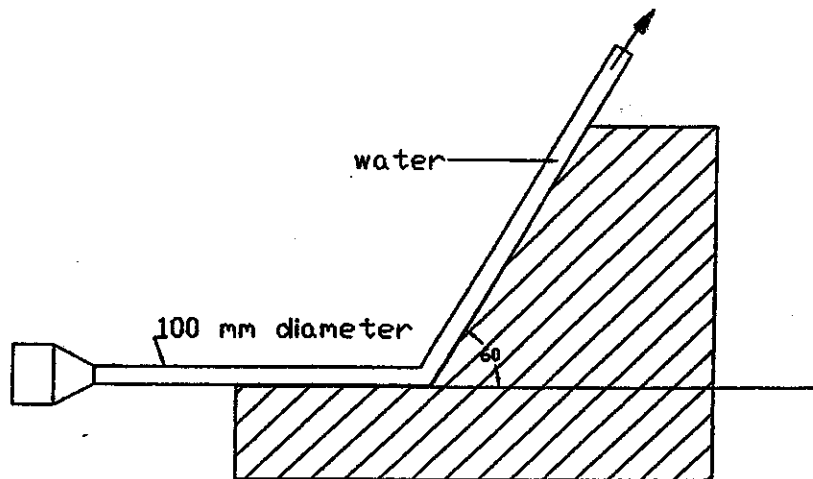

- (b) A jet of water 30mm diameter and velocity of 15 m/s strikes a flat stationary plate inclined at  $25^\circ$  to the water axis. Calculate the normal force exerted on the plate. Assume density of water is  $1000 \text{ kg / m}^3$ . [10 marks]

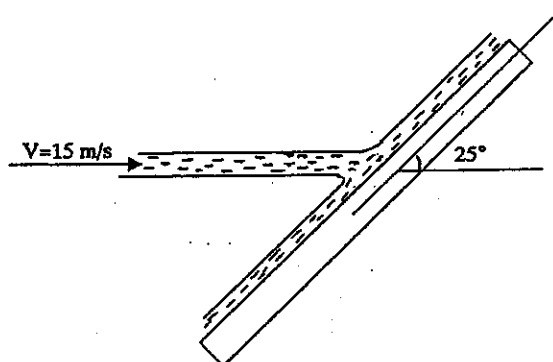

**Question 5**

(a) Define the following terms in connection with the flow of a liquid:

- i. Mass flow rate [2 marks]
- ii. Volume flow rate [2 marks]
- iii. Steady flow [2 marks]
- iv. Unsteady flow [2 marks]
- v. Uniform flow [2 marks]
- vi. Continuity [2 marks]

(b) Water flows in a circular pipe which reduces in diameter from 400mm at point A to 350mm at point B. The pipe then splits into two branches of diameters 150mm and 225mm discharging at C and D respectively. If the velocity at A and D is 1.0m/s, what is the discharge at C and D and the velocity at B and C? [13 marks]

## Question 6

(a) List the dimensions for the following:

i) Force [2 marks]

ii) Density [2 marks]

iii) pressure [2 marks]

(b) Show that the equation for pressure loss due to pipe friction, as shown below, is dimensionally homogeneous :

$$p = \frac{f \rho L v^2}{2d}$$

where

$p$  = pressure loss (Pa),

$d$  = pipe diameter (m),

$f$  = friction factor (dimensionless),

$\rho$  = fluid density ( $\text{kg/m}^3$ ),

$L$  = pipe length (m), and

$v$  = fluid velocity (m/s)

[9 marks]

(c) The speed of sound  $v$ , in a fluid is a function of pressure  $p$ , the density  $\rho$ , and the volume  $V$  of the fluid. Use dimensional analysis to determine the values of exponents  $x$ ,  $y$ , and  $z$  in the formula

$$v = C p^x \rho^y V^z$$

where  $C$  is a dimensionless constant.

[10 marks]